

Radiation	Type	Technology	Case
Infrared	ELD-810-095-2	AlGaAs/AlGaAs	TO-46

### Description

High-power, high-speed, double heterostructure with removed substrate, in TO-46 housing

### Applications

Optical communications, safety equipment, for encoders

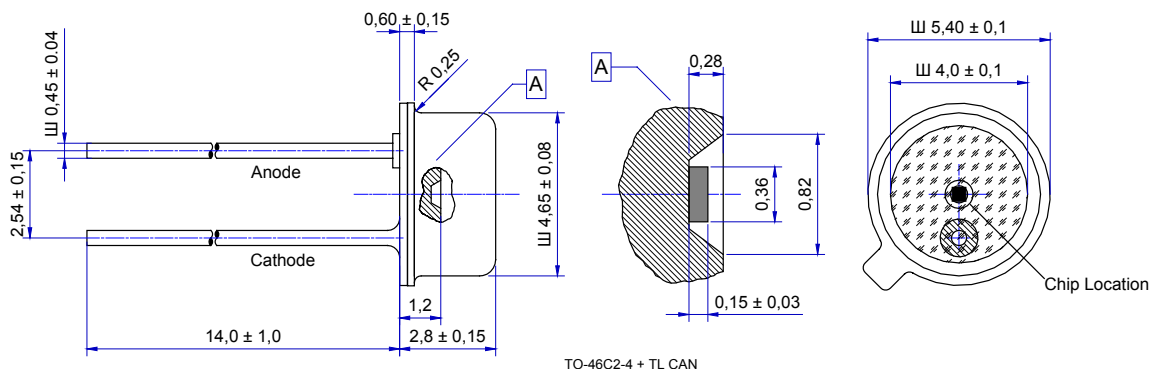

### Maximum Ratings

$T_{amb} = 25^{\circ}\text{C}$ , unless otherwise specified

Parameter	Test conditions	Symbol	Value	Unit
Forward current (DC)		$I_F$	100	mA
Peak forward current	$(t_P \leq 50 \mu\text{s}, t_P/T = 1/2)$	$I_{FM}$	200	mA
Surge forward current	$(t_P \leq 10 \mu\text{s})$	$I_{FSM}$	2000	mA
Reverse voltage	$I_R = 100 \mu\text{A}$	$V_R$	5	V
Operating temperature range		$T_{amb}$	-20 to +100	$^{\circ}\text{C}$
Storage temperature range		$T_{stg}$	-55 to +100	$^{\circ}\text{C}$
Mass		$m$	0.33	g

### Optical and Electrical Characteristics

$T_{amb} = 25^{\circ}\text{C}$ , unless otherwise specified

Parameter	Test conditions	Symbol	Min	Typ	Max	Unit
Forward voltage	$I_F = 100 \text{ mA}$	$V_F$		1.7	2.1	V
Radiant power	$I_F = 100 \text{ mA}$	$\Phi_e$		10		mW
Radiant intensity	$I_F = 100 \text{ mA}$	$I_e$		8		mW/sr
Peak wavelength	$I_F = 100 \text{ mA}$	$\lambda_p$	800	810	820	nm
Spectral bandwidth at 50%	$I_F = 100 \text{ mA}$	$\Delta\lambda_{0.5}$		35		nm
Viewing angle		$\varphi$		90		deg.
Switching time	$I_F = 100 \text{ mA}$	$t_r, t_f$		40		ns

