

Reception	Type	Technology	Case
Infrared	TOP-LED	AlGaAs/GaAs	PLCC-2

### Description

Narrow response range (740 nm peak)  
single heterostructure with substrate

### Applications

Spectral analytics  
Optical communications,  
safety equipment

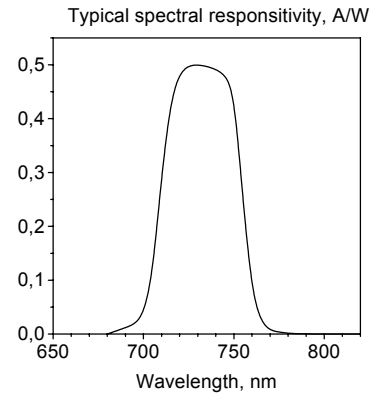
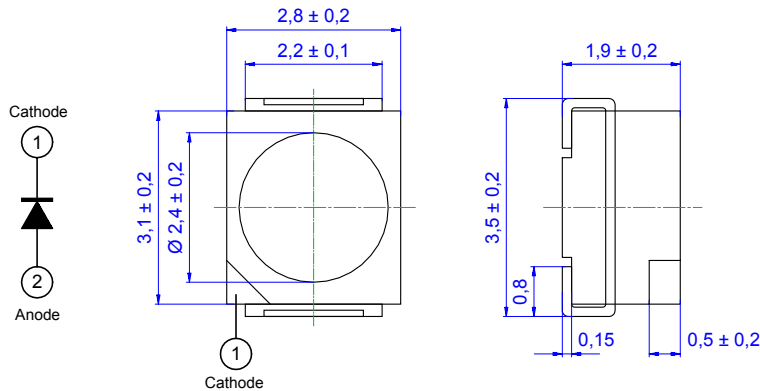

### Maximum Ratings

Parameter	Value	Unit
Storage temperature	-40...+90	°C
Operating temperature	-40...+85	°C
Soldering temperature	240	°C

### Optical and Electrical Characteristics

T<sub>amb</sub> = 25°C, unless otherwise specified

Parameter	Test conditions	Symbol	Min	Typ	Max	Unit
Active area		A		0.13		mm <sup>2</sup>
Peak sensitivity	V <sub>R</sub> = 0 V	λ <sub>Smax</sub>	700	740	780	nm
Responsivity at 740 nm	V <sub>R</sub> = 0 V	S <sub>λ</sub>		0.5		A/W
Spectral bandwidth at 50%	V <sub>R</sub> = 0 V	Δλ <sub>0,5</sub>		60		nm
Short-circuit current	V <sub>R</sub> = 0, E <sub>e</sub> = 1mW/cm <sup>2</sup>	I <sub>SC</sub>		1		μA
Dark current	V <sub>R</sub> = 5 V, E <sub>e</sub> = 0	I <sub>D</sub>		40	200	pA
Reverse voltage	I <sub>R</sub> = 10 μA	V <sub>R</sub>		10		V
Junction capacitance	V <sub>R</sub> = 0, E <sub>e</sub> = 0	C		40		pF
Rise time	R <sub>L</sub> = 50 Ω,	t <sub>r</sub>		15		ns
Fall time	V <sub>R</sub> = 5 V	t <sub>f</sub>		30		ns