

DC to 6GHz Ultra-Small Coaxial Switch

MS-147 Series

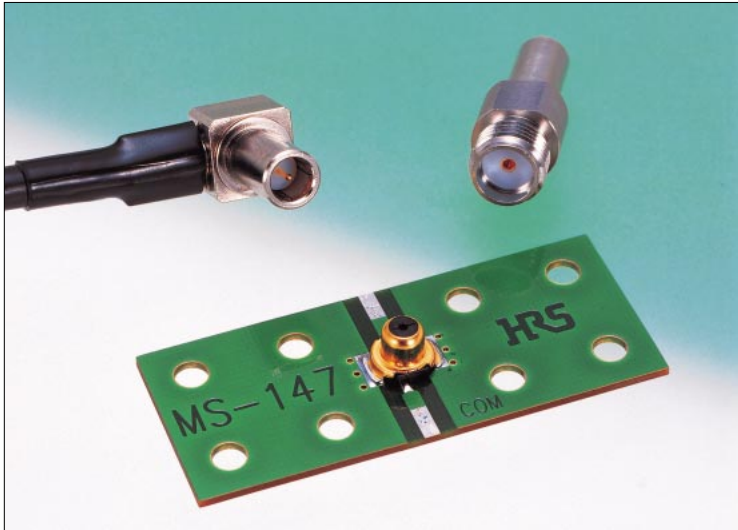

Outline

The ultra-small MS-147 coaxial switch series was developed for the portable terminal interface and for inspection of microwave boards (substrates) (DC – 6GHz) used at high frequencies.

To respond to the development of portable terminal technologies and popularization of high-frequency applications – up to 6GHz – this switch features low loss, low profile, and light weight.

The switch circuit is designed so that the NC terminal is connected to the C terminal without a plug mated. Mating with a plug opens this connection.

Vertical mounting structure allows the switch to be placed near the antenna of the portable terminal and used to inspect output and switch to an external antenna.

Features

1. Low insertion loss

Insertion loss is as low as:
0.15dB(or less)(Typically, 0.08dB at 1GHz)
(DC – 2GHz)(Typically, 0.1dB at 2GHz)

2. Space saving

External dimensions are 5.8mm x 5.4mm. Saves installation space.

3. Low profile

Switch height is 3.9mm.

4. Light weight

Switch weight is 0.11g

5. Long life

The switch is guaranteed for up to 12,000 mechanical operations.

6. Auto insertable

Available in embossey tape-and-reel auto-insertable format

7. Wide application range

Operating frequency from DC to 6GHz.

8. Prevention of flux float-off

Switch structure prevents flux float-off.

9. Self-alignment

The eccentricity for plug mating is ± 0.5 mm.

Application

- * Wireless communication
(Bluetooth, IEEE 802.11)
- * Machines
(Portable terminal, notebook PC, ETC, POS terminal, GPS terminal PDA, etc.)
- * Also suitable for other high-frequency machines.

Saves board mounting space:
Low profile: Height 3.9mm
Light weight: Weight 0.11g

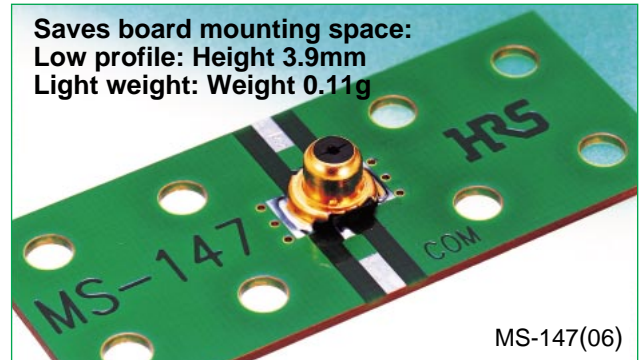

MS-147(06)

● Plug



MS-147-C(LP)-1

● SMA conversion adapter



MS-147-HRMJ-1

■Product Specification

Parameter	Unmated	Mated (MS-147-HRMJ-1)
Operating temperature range	-30°C ~ +85°C	-10°C ~ +65°C
Rated power	4 W	4 W
Frequency range	DC ~ 6 GHz	DC ~ 6 GHz
Insertion loss	0.15dB or less (DC ~ 2GHz) 0.2dB or less (2GHz ~ 3GHz) 0.4dB or less (3GHz ~ 6GHz)	0.2dB max. (DC ~ 2GHz) 0.3dB max. (2GHz ~ 2.5GHz) 0.4dB max. (2.5GHz ~ 3GHz) 0.8dB max. (3GHz ~ 6GHz)
Isolation	25dB or more (DC ~ 1GHz) 20dB or more (1GHz ~ 3GHz) 14dB or more (3GHz ~ 6GHz)	
V.S.W.R.	1.2 or less (DC ~ 3GHz) 1.5 or less (3GHz ~ 6GHz)	1.25 max. (DC ~ 2GHz) 1.3 max. (2GHz ~ 2.5GHz) 1.4 max. (2.5GHz ~ 3GHz) 1.9 max. (3GHz ~ 6GHz)

Parameter	Standard	Test Condition
1.Contact resistance	Center 75mΩ or less External 50mΩ or less	Measured at 100mA or less.
2.Insulation resistance	1,000MΩ or more	Measured at 100VDC
3.Dielectric strength	No flashover or breakdown	100V AC applied for one minute
4.Resistance to Vibration	No electrical discontinuity for 10μs or more.	Frequency: 10Hz ~ 55Hz, full amplitude 1.5mm in three axial directions for two hours each
5.Resistance to Shock	No electrical discontinuity for 10μs or more.	Acceleration: 490m/S ² , half sine-wave in three directions for three times each.
6.Resistance to moisture	Contact resistance: Center 100mΩ or less External 75mΩ or less Insulation resistance 10MΩ or more	Temperature: 40°C, humidity: 90% to 95% after 96 hours
7.Thermal shock	Contact resistance: Center 100mΩ or less External 75mΩ or less Insulation resistance 10MΩ or more	Temperature cycle: -55→5 ~ 35 →85→5 ~ 35°C Time: 30→5 minutes max. →30→5 minutes max. 100 cycles
8.Resistance to Corrosion	Contact resistance: Center 100mΩ or less External 75mΩ or less No excessive corrosion	Salt water concentration 5%, temperature 35°C, duration 48 hours
9.Long life	Contact resistance: Center 100mΩ or less External 75mΩ or less	12,000 mating cycles

■Materials

Part	Material	Color/Finish	UL standard
Shell	Phosphor bronze	Gold plating	—————
Insulation case	Polyamide resin	—————	UL94HB
Common terminal	Beryllium copper	Gold plating	—————
Board circuit side (NC) terminal	Beryllium copper	Gold plating	—————

High Frequency Characteristics (Typical)

● NORMAL CLOSE (N.C)

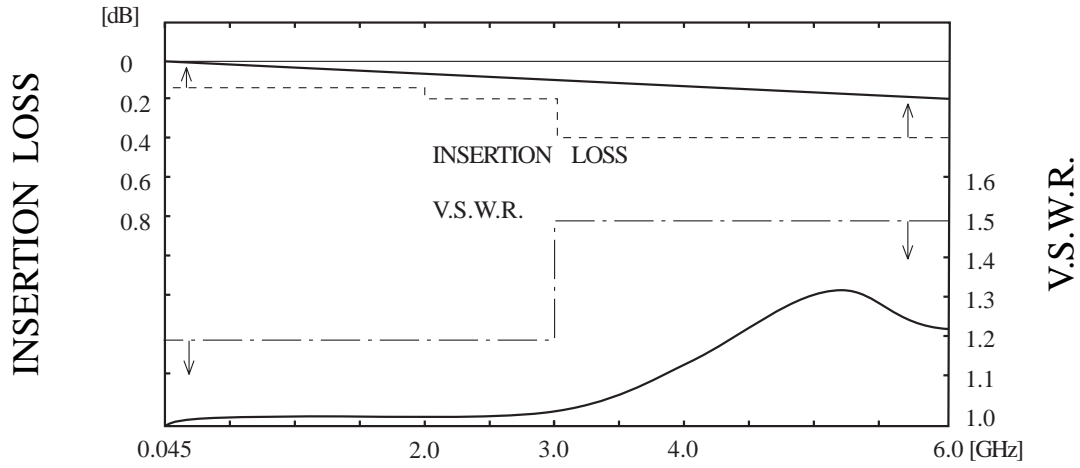

● NORMAL OPEN (N.O)

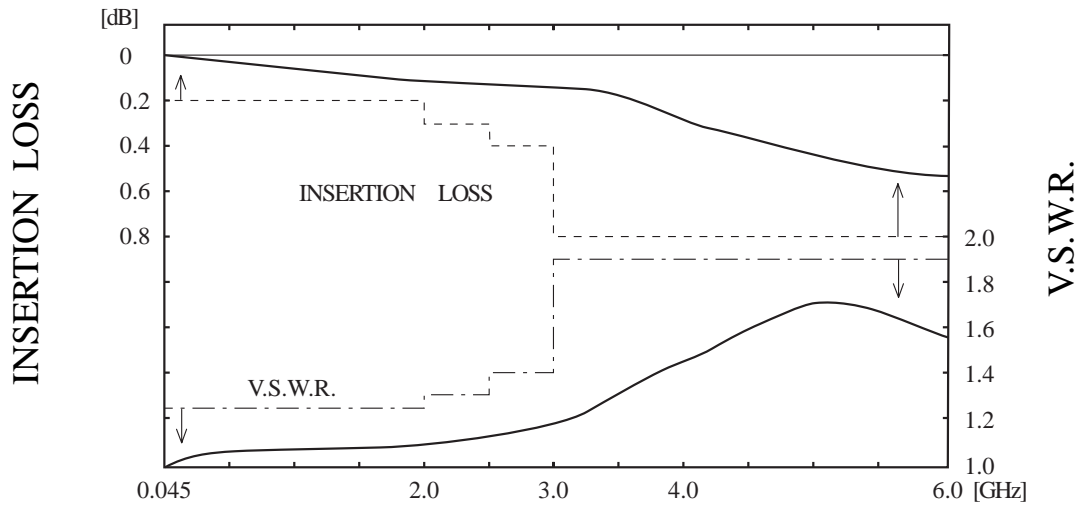

● ISOLATION

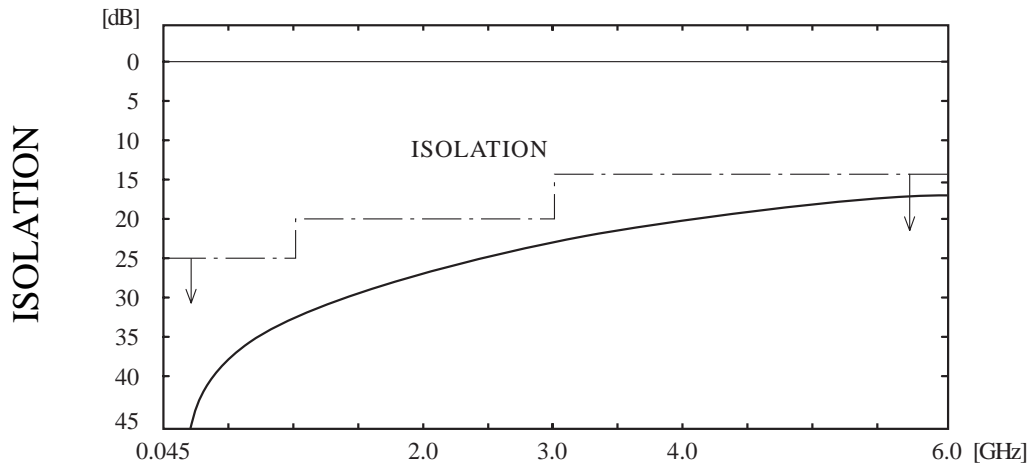

■ Receptacle

Product No. MS-147 (06)
Packed quantity: 1,500 pieces per reel

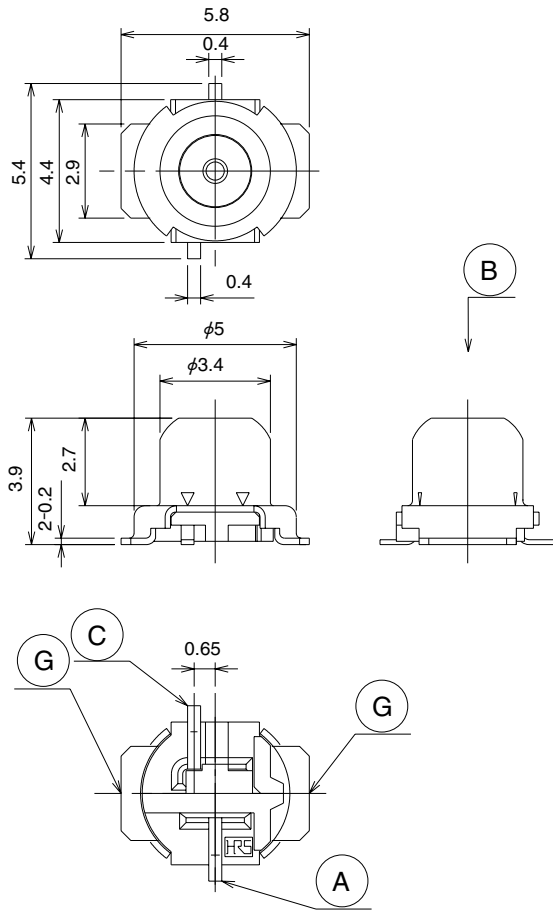

■ Circuit diagram

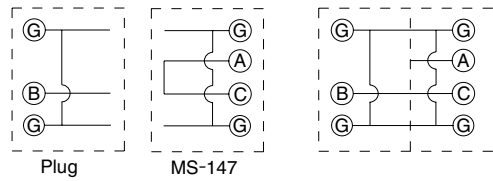

■ Recommended land pattern dimensions

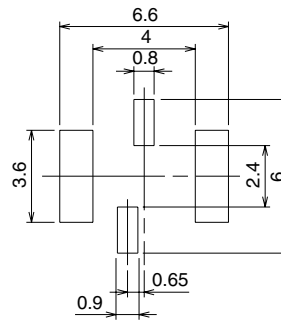

■ Embossed tape carrier dimensions per JIS C 0806

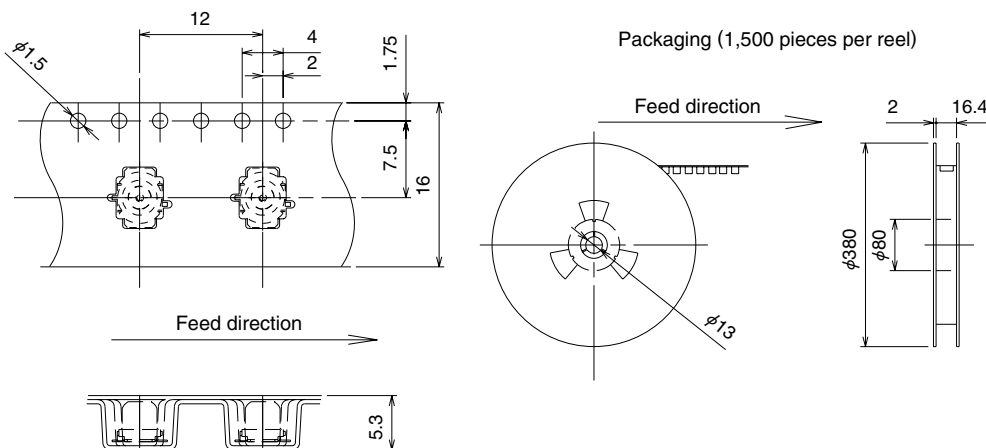

■ Plug

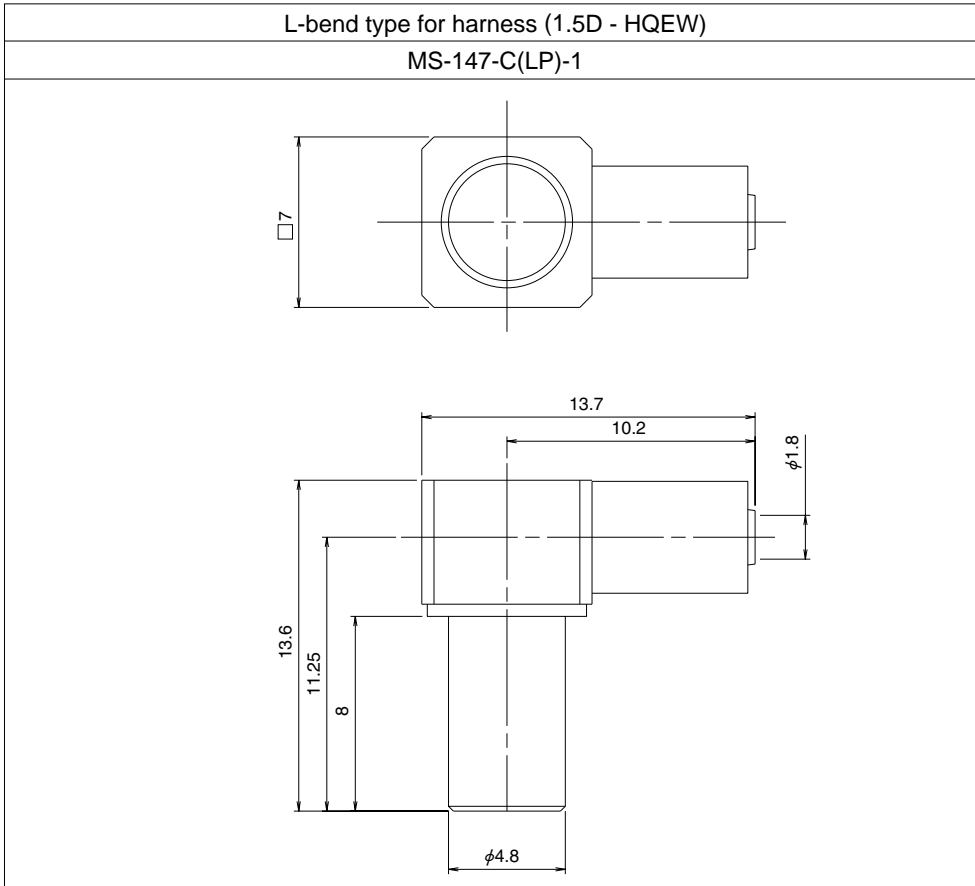

■ SMA conversion adapter

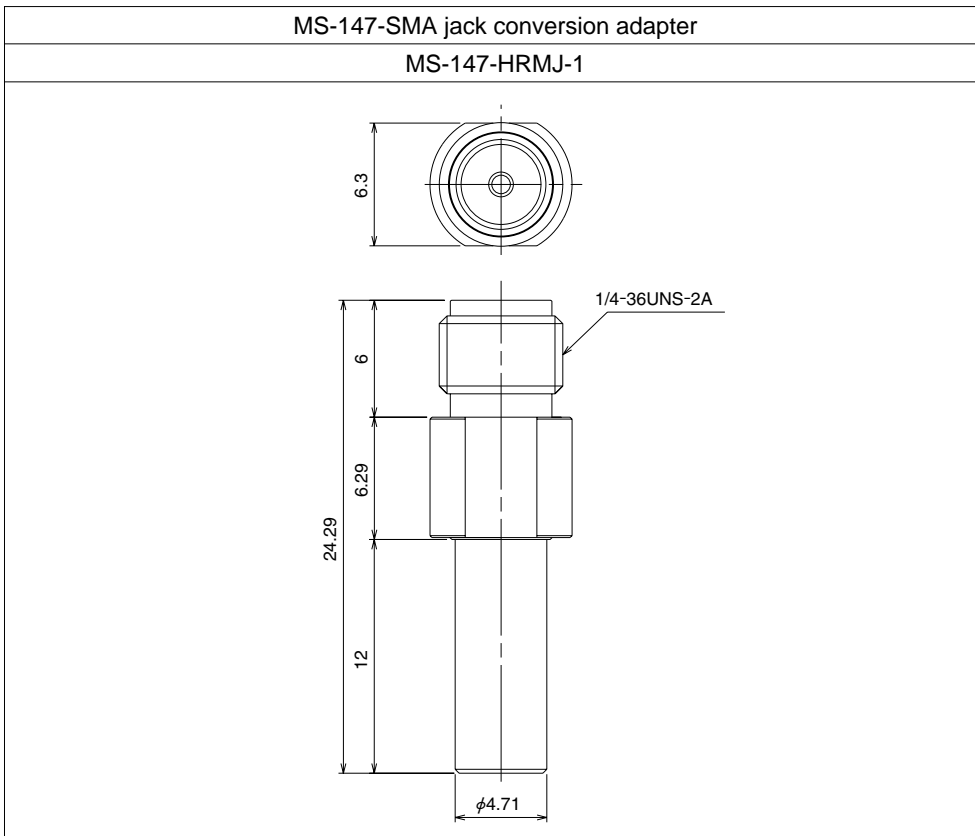

Recommended Reflow Conditions

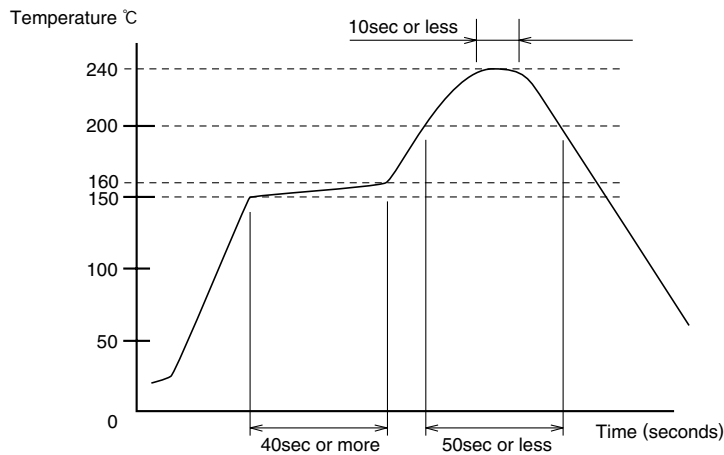

● Maximum temperature	: 240°C
● Duration of peak temperature	: 10sec or less
● Base peak temperature	: 220°C – 235°C
● 200°C or over	: 50sec or less
● 150°C – 160°C	: 40sec or more

Example of Application

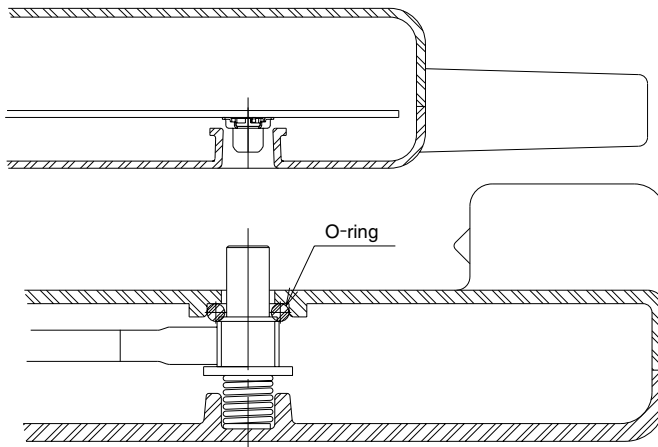

Note: Mounting example

Recommended Nozzle Profile

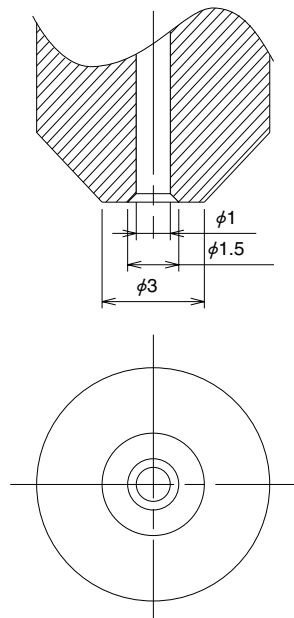

■Precautions

1. Compatible with the following plugs.

MS-147-C(LP)-1 : Plug harness type
(Effective mating length: 0.87mm min.)

MS-147-HRMJ-1 : SMA conversion adapter
(Effective mating length: 0.87mm min.)

2. Not washable.

3. Design the mounting holes with sufficient clearance to protect the switch from being subjected to excessive force should the board be dropped.

4. For RF interface application for portable terminals, cover the plug entry with a rubber cap to keep dust out when no plug is inserted.

5. Be sure to fully insert the plug until it contacts part P.

