

Subminiature Ceramic Couplers(suited to SMT)

HD-S Series

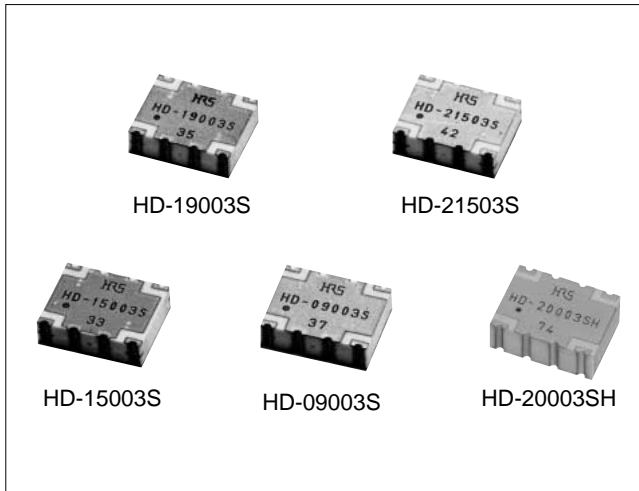

Features

1.Subminiature Design

Hirose Electric's expertise in miniaturization and matching technology has permitted a subminiature, lightweight design.

2.High Performance

The high frequency characteristics feature extremely low loss and a high degree of matching which makes these couplers ideal for a wide variety of wireless phone base station applications.

3.Suited to Automatic Mounting

Embossed tape packaging permits automatic mounting.(Individual delivery can also be accommodated.)

Product Specifications

Rating	Frequency range (NOTE) Characteristic impedance Maximum usable power (NOTE)	800 to 2300 MHz 50Ω 10 to 50 W	Operating temperature range Operating relative humidity	-10°C to +65°C 95% or less
--------	---	--------------------------------------	--	-------------------------------

NOTE: The frequency range and the maximum usable power will differ depending on the model.

Item	Standard	Conditions
1.Insulation resistance	1000 MΩ min.	Measured at 100 V DC
2.Vibration resistance	No electrical disconnections of 1μs or greater Contact resistance: 1000 mΩ max. No damage, cracks, or parts looseness	Frequency of 10 to 500 Hz, overall amplitude of 1.52 mm, 98 m/s ² acceleration, in 3 axial directions, 2 hours each
3.Shock resistance	No electrical disconnections of 1μs or greater Contact resistance: 1000 mΩ max. No damage, cracks, or parts looseness	980 m/s ² acceleration, half sine wave, in 3 axial directions, 3 times each
4.Temperature cycle	Contact resistance: 1000 mΩ or less Insulation resistance: 1000 MΩ min. No damage, cracks, or parts loosenes	(-55°C: 30 min. → 5 to 35°C: Within 15 min. → 85°C: 30 min. → 5 to 35°C: Within 15min.) for 200 cycles

●The test method conforms to MIL-STD-202.

Materials

Part	Material	Processing
Case	Ceramic	Solder plating

Production Number Breakdown

HD - 090 03 S
① ② ③ ④

① Series Name: HD (Directional Couplers)	③ Degree of Coupling 03 : 3dB 10 : 10dB 16 : 16dB 21 : 21dB 23 : 23dB
② Center Frequency 090 : 900MHz 150 : 1500MHz 190 : 1900MHz 200 : 2000MHz 215 : 2150MHz	④ Board Mounting Method S : SMT SH : SMT High Power

Recommended Board Pattern

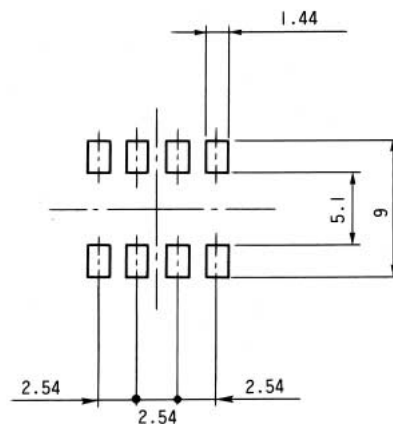

●Resist processing should be performed around the electrode pads.

■ Specifications

Model No.	(MHz) Frequency Range	(dB) Coupling	Frequency Sensitivity	(dBMax) Insertion Loss	(dB Min) Isolation	(dB Min) Directivity	(Max) V.S.W.R.	(g) Weight	(W) Power
HD-09003S	800~1000	3 ⁺⁸	±0.35	—	20	—	1.22	0.6	10
HD-09010S	840~ 960	10±1	±0.4	0.4	—	15	1.3	0.6	20
HD-09016S	840~ 960	16±1	±0.4	0.4	—	15	1.3	0.6	20
HD-09023S	840~ 960	23±1	±0.4	0.4	—	15	1.3	0.6	20
HD-15003S	1400~1600	3 ⁺⁸	±0.35	—	20	—	1.2	0.6	10
HD-15010S	1400~1600	11±1	±0.4	0.4	—	15	1.25	0.6	20
HD-15016S	1400~1600	16±1	±0.4	0.4	—	10	1.35	0.6	20
HD-15021S	1400~1600	21±1	±0.4	0.4	—	10	1.35	0.6	20
HD-19003S	1850~1950	3 ⁺⁸	±0.5	—	20	—	1.2	0.6	20
HD-21503S	1900~2300	3 ⁺⁸	±0.5	—	20	—	1.25	0.6	20
HD-20003SH	1900~2200	3 ⁺⁸	±0.4	—	20	—	1.25	0.7	50

- The coupling loss component is not included in the insertion loss. ●There is a 90° phase difference between the output and the coupling.
- When ordering embossed tape packaged items, affix (06) to the end of the product number. One reel contains 1,000 pieces.

■ External Dimensions

HD-09003S HD-09023S HD-15016S HD-21503S
 HD-09010S HD-15003S HD-15021S
 HD-09016S HD-15010S HD-19003S

HD-20003SH

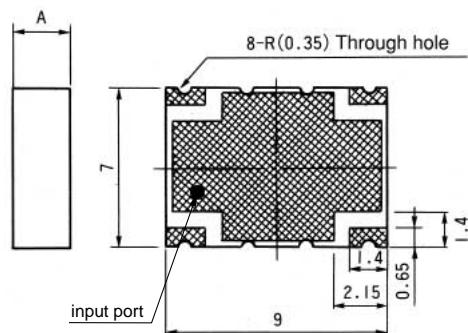

Degree of Coupling	A
3dB	2.6
10dB	1.6
16dB	1.6
21dB	1.8
23dB	1.8

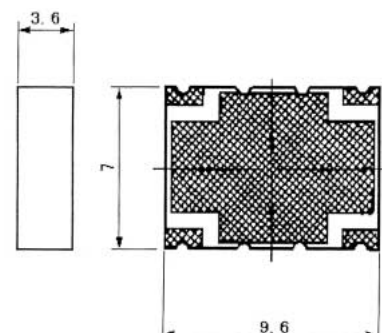

■ Usage Precautions

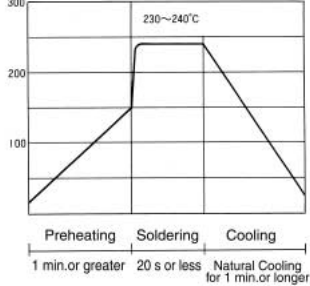
<p>1. Soldering</p> <p>(1) Recommended temperature profile</p> <p>(2) Recommended hand soldering conditions</p> <p>(3) Recommended screen thickness</p>	 <p>① Up to two cycles are permitted at the same conditions provided that the item is at room temperature between the first and second cycle.</p> <p>② The temperature indicates the board surface temperature of the contact lead portion.</p> <p>③ Reflow soldering should be performed at a peak temperature of 240°C or less at the surface of the printed circuit board.</p> <p>④ The temperature profile will change depending on the conditions which include board size, solder used, and solder thickness.</p> <p>Soldering iron temperature: 350°C, Soldering time: Within 5 s 0.15 mm</p>
<p>2. Product Storage</p>	<p>① After opening the package reseal promptly or store in a desiccator with a desiccant.</p> <p>② Store in a place that is not exposed to harmful gases which include sulfur or chlorine, etc.</p> <p>③ Use within one year of delivery.</p>